

 UNION PROCESS®



**DRY GRINDING
ATTRITORS**



Dry Grinding Attritors

SD, HSA, and Lab Series

History



From a revolutionary idea proposed and developed by Dr. Andrew Szegvari in 1945, Attritor technology grew to become the basis for Union Process, Inc., an independent, privately held American company founded in Akron, Ohio. Today, Attritors are considered to be the most efficient grinding/dispersing systems and are used in scores of

industries and research laboratories worldwide. More recently, Union Process has developed Attritors specifically designed for the dry grinding process.

Continuous or Batch Operation

SD Series

The SD Dry Grinding Attritors can be operated in both continuous and batch processing applications. In the continuous operation, the material is fed into the vessel at the top. It then migrates through the agitating media bed where it is processed to a desired particle size and is discharged through metering bar grids at the bottom of the tank.

In the batch mode, material is charged into the mill at the top, ground for a predetermined time, then discharged through grids at the bottom. The system can easily be sealed for grinding under inert gases such as nitrogen or argon.

The SD Attritor is also used to make dispersion-strengthened metal (DSM). In this process (known as mechanical alloying or cold welding), the kinematic porosity results in the grinding media breaking the metals into small particles and beating them together to form agglomerates. By repeating the process, the various metals are evenly mixed and dispersed to form a new composition of alloy (DSM).

HSA Series

The HSA High Speed Attritor is generally used in a continuous mode. The material is charged into the mill at the top and is discharged out the bottom side, making use of centrifugal force. The HSA is used when smaller particle size (generally 40 mesh) materials are fed into the machine and micron size end product is desired.

Also, it is often used for fibrous types of materials.

The Dry Grinding Process

The Attritor dry grinding process is achieved in a stationary tank by means of a rotating shaft and arms that agitate the media into a random state of motion of internal porosity called kinematic porosity. In this expanded condition, the media and particles are free to move, collide and impinge upon each other.

KINEMATIC POROSITY

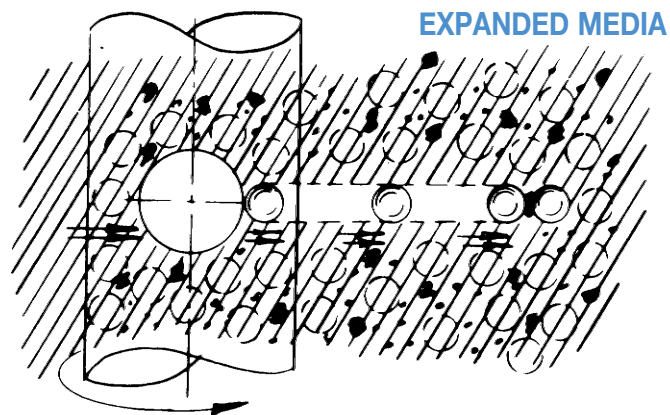

Revolving arm hits grinding media

Media moves forward rapidly

Media collides with media, breaking up product particle

MEDIA AT REST

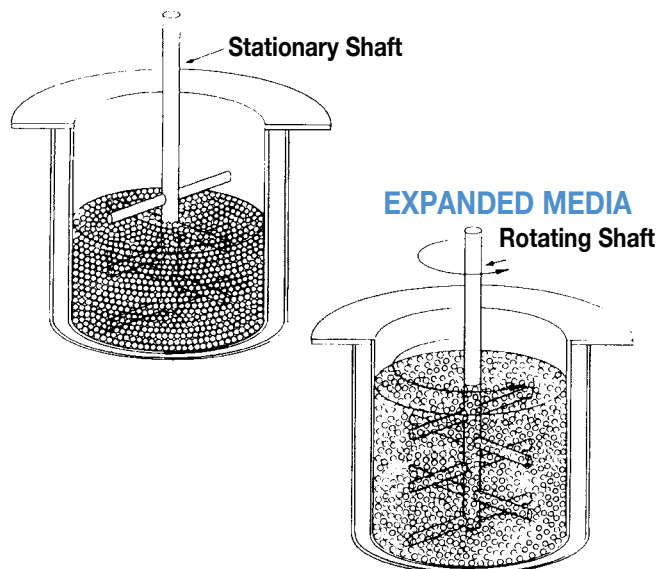

Stationary Shaft

EXPANDED MEDIA

Rotating Shaft

SD SERIES

Union Process SD Dry Grind Attritors are ruggedly built machines with specially designed, VFD motors. They are also equipped with jacketed, stainless steel tanks and tilting mechanisms for ease of cleaning and maintenance.

Features and Options

- All eight models can be outfitted to operate in either batch or continuous mode.
- All models equipped with ammeter.
- When metal contamination must be eliminated, tank liners and arm sleeves of tungsten carbide or various ceramics can be applied.
- Cover seals can be provided for conditions where dust control is desired, or where grinding must be done under a closed inert gas system.
- Media discharge valves can also be installed.
- Variable frequency drives and controls are available.



SDL-50 Attritor
Special cover with brush seal and vent and metering discharge valve assembly. 75 HP, variable frequency drive, TEFC electricals. CE Marked.



SD-30 Attritor
Sealed cover with ceramic-lined tank, zirconium oxide sleeved arms, and actuated discharge assembly. Explosion-proof electricals.

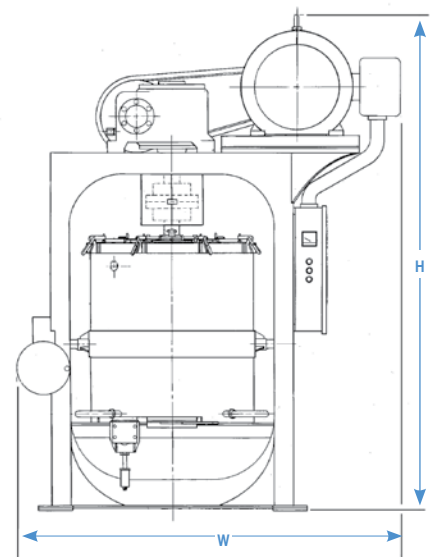
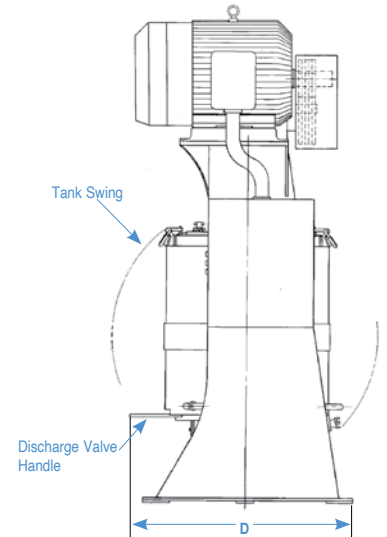

ENGINEERING DATA								
	Open Frame					A-Frame		
ATTRITOR MODEL	SD-5	SD-10	SD-15	SD-30	SD-50	SD-100	SD-200	SD-250
Gross Tank Volume (gals)	9	16	24	52	81	155	255	288
Material Capacity (gals)	2-3	4-6	5-7	10-18	15-25	30-50	60-100	75-125
Media Volume (gals)	5	9	12	25	37	75	150	187
HP*	10-15	20-25	25-40	40-60	75-100	100-150	200-250	250-350
Height (H)	81"	87"	89"	96"	107"	114"	137"	163"
Floor Space (W x D)	38"x55"	40"x55"	40"x60"	60"x75"	72"x86"	87"x62"	106"x80"	152"x89"
Machine Weight (lbs) w/o media	2000	2400	2800	3500-5500	4500-6000	5600-7900	11,000-14,000	14,000-16,000

VARIOUS TYPES OF CERAMIC LININGS ARE AVAILABLE FOR ALL MODELS

* For ceramic media, less horsepower is required.

On Cover: Model SD-200 Dry Grinding Attritors with ASME coded cooling water jackets for special closed loop cooling system.

LAB MODELS

SD-1 Attritor

The SD-1 Attritor is a versatile, reliable, rugged laboratory-size machine. It comes standard with a VFD (variable frequency drive), water-jacketed grinding tank, cover with brush seal, and bottom discharge grid with metering valve or ball valve. For metal-free grinding, various ceramic liners are available. Picture shows SD-1 equipped for grinding under inert gases with a MECO shaft seal and sealed discharge pot mounted on movable stand. See *Laboratory Grinding Mills brochure for more information*

HSA-1 Attritor

The HSA-1 High Speed Attritor is sized for laboratory and research studies. The HSA-1 works on the same principle as the production machines and discharges through a side screen and valve.

The standard HSA-1 is equipped with a 5 HP VFD (variable frequency drive), and it has a water jacket for cooling. Picture shows mill with the addition of temperature probes for monitoring the cooling water in and out, a MECO shaft seal for grinding under inert gases, and a metered powder feeder.

HD-01 Attritor

This unit is available if one has a limited amount of material. It comes with a VFD (variable frequency drive). It can be equipped with a MECO shaft seal for grinding under inert gases. Grinding chamber is water jacketed. See *Laboratory Grinding Mills brochure for more information*.



SD-1 Attritor



HSA-1 Attritor



HD-01 Attritor

Standard power for all lab machines is 230/460V, 3 phase.			
Model	SD-1 Series Electronic Drive		HSA-1 Series Electronic Drive
Tank Capacity (gal)	1.5	2.5	1.3
Working Capacity (gal)	0.7	1.1	0.4
Media Volume (gal)	1.0	1.5	0.3 - 0.5
HP—Standard Dry Grinding	3 HP	5 HP	5 HP
HP—DSM (mechanical alloying)	5 HP	7½ HP	—
Height (inches)	46		43
Bench Space (WxD in inches)	26x50	26x50	22x32
Machine Weight (lbs) w/o media	750	750	600

Models are available with TEFC or explosion-proof electrical systems.

Common applications for Dry Grinding Attritors

- Ceramic powders
- Glass frits
- Metal powders
- Mechanical alloying
- Metal oxides
- Fibers and cellulose
- Food products
- Ferrite
- Pigments
- Minerals
- Coal and coke
- Graphite
- Plastics and rubbers
- Chemicals
- Batteries

HSA SERIES

HSA Attritors feature a patented design concept that includes a unique grinding tank internal configuration which allows higher shaft speeds, finer grinding, and continuous operation with side discharge.

A series of specially shaped agitating arms and diverter discs are mounted along the longitudinal axis of the agitator shaft. This engineering design makes it possible to use smaller grinding media, operate at higher shaft RPM, and increase residence time of the material to be processed to insure a finer grind.

Features and Options

- Fully integrated system
- Stainless steel grinding chamber
- High speed, high volume production
- Equipped with ammeter
- Fully jacketed grinding tank for temperature control
- T.E.F.C. or explosion-proof electricals available
- Efficient side discharge
- Can be equipped with a metering pump for grinding aid
- Exceptionally fine grinding

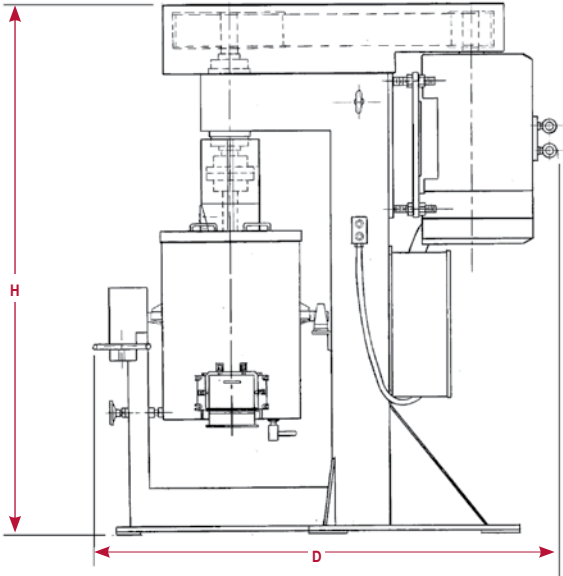

HSA-30 Attritor

HSA-100 Attritor

ENGINEERING DATA					
ATTRITOR MODEL	HSA-10	HSA-20	HSA-30	HSA-50	HSA-100
HP	25	50	60	100	200
Gross Tank Volume (gal)	10.3	18.7	28.6	43.4	85.0
Media Volume* (gals)	3.8	7.6	11.4	19.0	38.0
Height (H)	87"	90"	92"	100"	120"
Floor Space (W x D)	33"x 68"	34"x 73"	45"x 74"	46"x 91"	52"x 98"
Discharge Height (X)	21"	16"	13"	16"	16"
Machine Weight (lbs) w/o media	2800	3500	4000	5400	8400

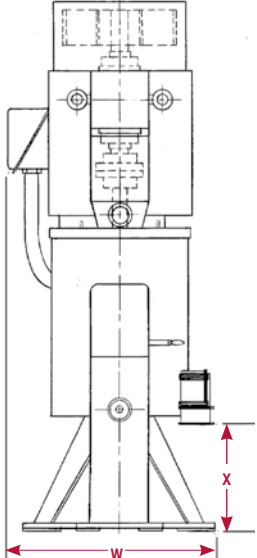

* May vary depending on application.

The Union Process Advantage

From years of experience in designing and building thousands of Attritors for hundreds of applications, Union Process has developed the “know-how” needed to custom design units for specific requirements, whether for production or laboratory use, employing either a dry or wet grinding process. Union Process maintains a well-equipped laboratory and pilot plant where actual production conditions can be

simulated to assure that the Attritor we build for you will satisfy your requirements. Skilled technical service representatives are available for consultation. They can arrange visits to customer and prospective customer facilities to answer questions and provide solutions.



Installation of an HSA-100 for continuous fine dry grinding of calcium carbonate and barites.

Grinding Media

Union Process offers a large selection of highest quality grinding media including stainless steel, chrome steel, carbon steel, ceramic, tungsten

carbide, zirconium oxide, silicon carbide, silicon nitride and more. Most are available in different sizes to meet your specific grinding requirements.

A Union Process representative can advise you about which grinding media is best for your application.



For information on our broad line of grinding and dispersing equipment, please visit our website at www.unionprocess.com.



1925 Akron-Peninsula Road, Akron, Ohio 44313-4896

Phone: (330) 929-3333

E-mail: unionprocess@unionprocess.com

Web: www.unionprocess.com

Union Process, Inc. reserves the right to make improvements or change machine and equipment designs at any time without notice. Information contained herein is accurate and reliable to the best of our knowledge, but our suggestions and recommendations cannot be guaranteed because the conditions of use are beyond our control.

Apparatus, Process and/or Product protected under one or more of the following U.S. Patents: 4,979,686; 5,080,293; 5,199,656 and other pending patent applications as well as corresponding and related foreign patent rights.